

SA304-W1 Contoured Cable Cover

Parts and Hardware

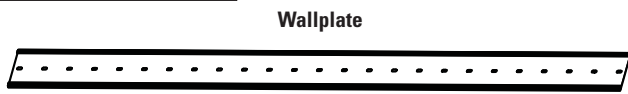

Wallplate

01

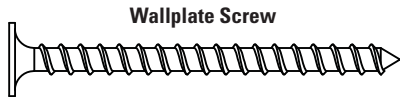

Wallplate Screw

#8 x 2 in.

02 (4)

Concrete/Drywall Anchor

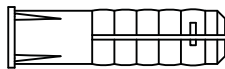

03 (4)

Wallplate Washer

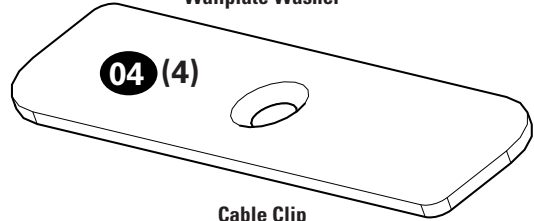

04 (4)

Cable Clip

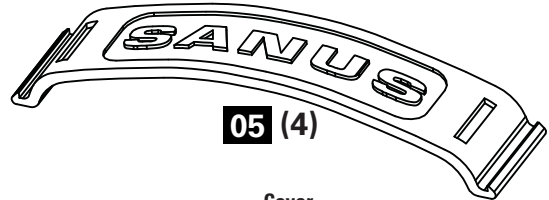

05 (4)

Cover

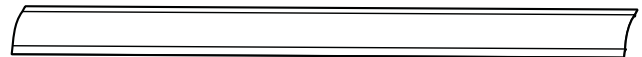

06

Required Tools

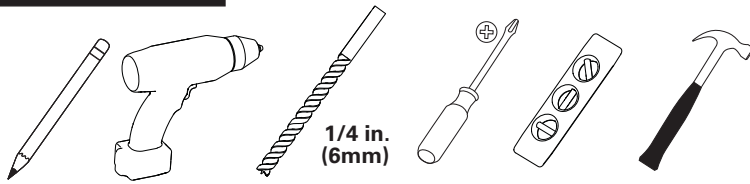

1/4 in.
(6mm)

Optional Tools

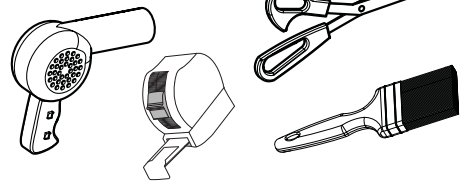

NOTE: SA304 can be painted. Use primer for vinyl and latex paint.

NOTA: SA304 puede haber imprimación painted. Use de vinilo y pintura de látex.

NOTE 1: If wallplate and cover do not "relax" after unpacking, use a hairdryer on low heat setting.

NOTA 1: Si la placa mural y la cubierta no se "suavizan" después de quitarlas del empaque, utilice un secador de pelo a temperatura media.

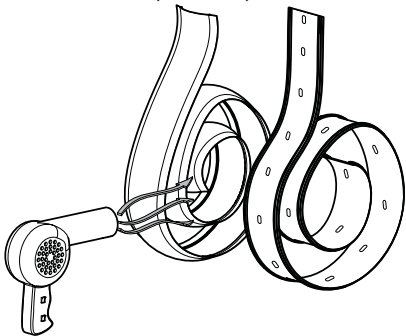

NOTE 2: Wallplate and cover may be cut if required.

NOTA 2: De ser necesario, la placa mural y la cubierta se pueden cortar.

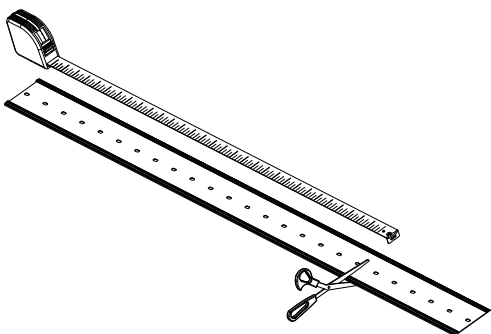

STEP 1

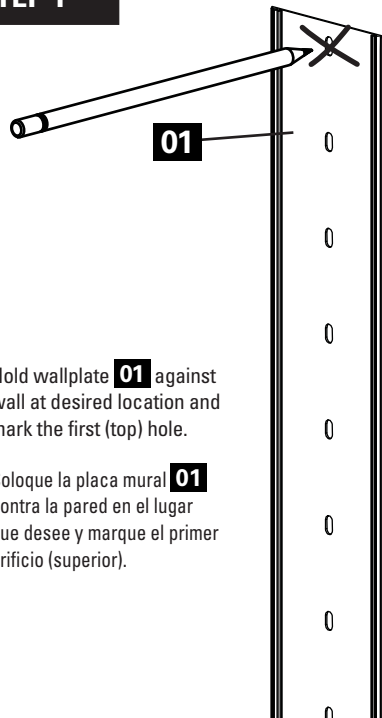

Hold wallplate **01** against wall at desired location and mark the first (top) hole.

Coloque la placa mural **01** contra la pared en el lugar que desee y marque el primer orificio (superior).

STEP 2

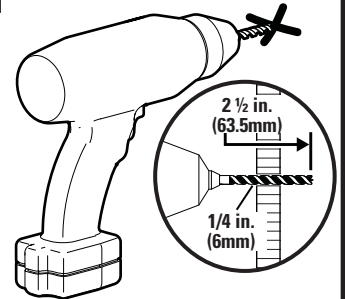

Drill hole using 1/4 in. (6mm) drill bit where marked and insert a wall anchor **03**.

IMPORTANT: If mounting to a wood stud do not predrill a hole or use the concrete/drywall anchors **03**.

Con una mecha de 6mm (1/4 pulgadas) haga un orificio donde esté la marca e inserte un anclaje **03**.

¡IMPORTANTE! Si se instala en un montante, no necesita preperforar ni usar un anclaje **03**.



NOTE: When using concrete/drywall anchors, be sure they seat flush with the surface of the wall.

NOTA: Al utilizar anclajes de hormigón / mampostería seca, asegúrese de que asienten al ras con la superficie de la pared.

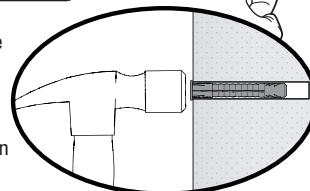

STEP 3

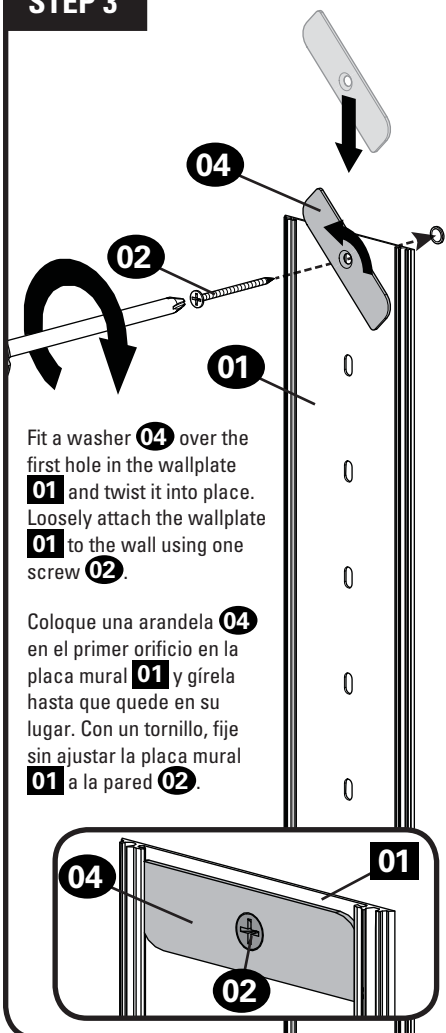

Fit a washer **04** over the first hole in the wallplate **01** and twist it into place. Loosely attach the wallplate **01** to the wall using one screw **02**.

Coloque una arandela **04** en el primer orificio en la placa mural **01** y gírela hasta que quede en su lugar. Con un tornillo, fije sin ajustar la placa mural **01** a la pared **02**.

STEP 4

Use a level to align the wallplate **01**. Make sure the wallplate **01** is flush against the wall and mark three more hole locations.

IMPORTANT: One hole location should be at the bottom hole of the wallplate **01**. Evenly space the remaining hole locations.

Nivele la placa mural **01** asegurándose de que **01** quede al ras de la pared y marque las posiciones de los tres orificios restantes.

IMPORTANTE: Uno de los orificios debe coincidir con el orificio inferior de la placa mural **01**. Distribuya el resto de los orificios a la misma distancia.

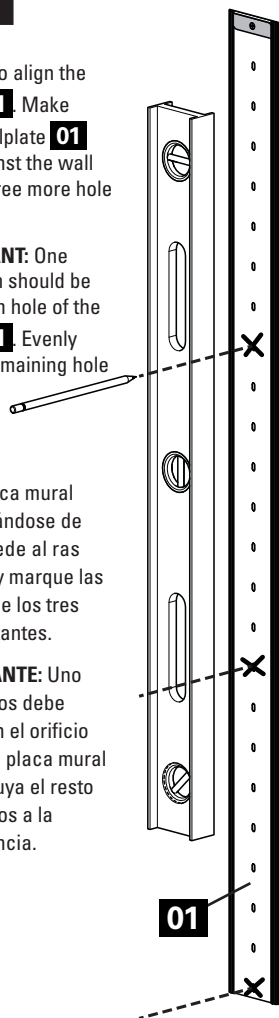

STEP 5

Swing the wallplate **01** out of the way and drill the three hole locations.

Gire la placa mural **01** para despejar el lugar y poder perforar los tres orificios.

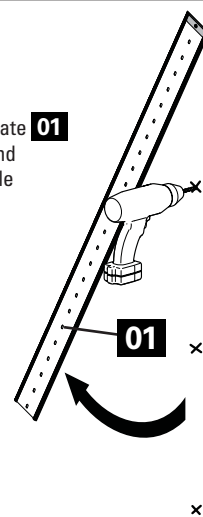

Insert concrete/drywall anchors **03**.

Coloque los anclajes **03**.

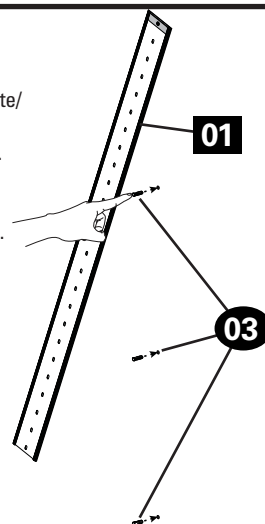

STEP 6

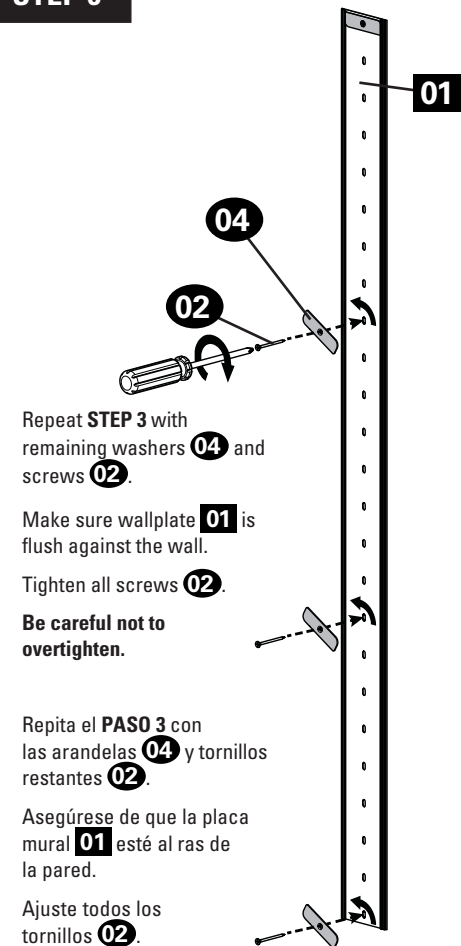

Repeat **STEP 3** with remaining washers **04** and screws **02**.

Make sure wallplate **01** is flush against the wall.

Tighten all screws **02**.

Be careful not to overtighten.

Repita el **PASO 3** con las arandelas **04** y tornillos restantes **02**.

Asegúrese de que la placa mural **01** esté al ras de la pared.

Ajuste todos los tornillos **02**.

Tenga cuidado de no ajustarlos demasiado.

STEP 7

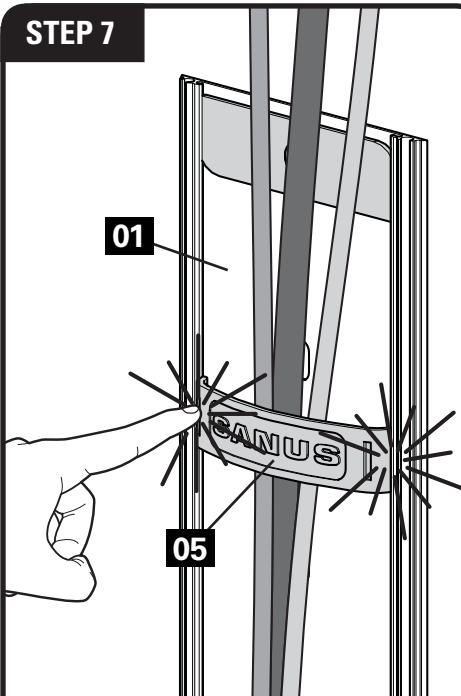

Run wires/cables down the length of the wallplate **01**. Secure with cable clips **05**.

Press ends of the cable clips **05** firmly until they "click" into place.

Pase los cables a lo largo de la placa mural **01**. Sujételos con presillas **05**.

Presione firmemente los extremos de las presillas **05** hasta que escuche el "clic" que indica que encajaron en su lugar.

STEP 8

Install cover **06** onto the wallplate **01**.

Press firmly on both sides of cover **06** working down the length.

The extrusions of the cover **06** should snap into the grooves of the wallplate **01**.

Coloque la cubierta **06** en la placa mural **01**.

Presione firmemente ambos lados de la cubierta **06** y desplácese hacia abajo.

Las extrusiones de la cubierta **06** deben cortarse en las ranuras de la placa mural **01**.

