

ACTpro-120

Installation and Configuration Instructions



VANDERBILT

Document ID: A-100661

Edition date: 29.06.2020

Data and design subject to change without notice. / Supply subject to availability.

© 2020 Copyright by Vanderbilt International Ltd.

We reserve all rights in this document and in the subject thereof. By acceptance of the document the recipient acknowledges these rights and undertakes not to publish the document nor the subject thereof in full or in part, nor to make them available to any third party without our prior express written authorization, nor to use it for any purpose other than for which it was delivered.



<http://van.fyi?Link=ACTpro-120>

Hereby, Vanderbilt International (IRL) Ltd declares that this equipment type is in compliance with the following EU Directives for CE marking:

- Directive 2014/30/EU (Electromagnetic Compatibility Directive)
- Directive 2014/35/EU (Low Voltage Directive)
- Directive 2011/65/EU (Restriction of the use of certain hazardous substances Directive)

The full text of the EU declaration of conformity is available at: <http://van.fyi?Link=DoC>



Table of Contents

1 Overview	4
1.1 ACTpro-120 features	4
1.2 Technical specification	4
1.3 Electrical specification	4
1.3.1 PSU output voltage	5
1.4 Power budget	5
1.4.1 Example power budget	5
1.5 Ordering information	6
2 Installation	7
2.1 Mounting	7
2.2 AC power up	7
2.3 AC power up (USA)	8
2.4 Battery insertion	8
3 Wiring	9
3.1 Wiring the ACTpro-120	9
3.2 DIP switch addressing	10
3.3 Wiring Clock&Data entry and exit readers	11
3.4 Wiring Wiegand entry and exit readers	12
3.5 Wiring Door Contact	13
3.6 Wiring Push Button (PB)	13
3.7 Break Glass monitoring only	14
4 Monitoring	16
5 Status Indicators	17
6 LED Indicators	18

1 Overview

The ACTpro-120 is a door station for a single door, with an integrated 12V 2A DC power supply. It expands any of the existing ACTpro controllers by one door.

1.1 ACTpro-120 features

- Main relay and AUX relay
- Supports all ACTpro readers (RFID 125KHz, MIFARE Classic, DESFire EV1)
- Break glass monitoring
- Voltage monitoring
- Supports clock and data or Wiegand readers
- Multiple entry and exit readers
- Reader current limiting / short circuit protection
- Request to exit
- Door monitoring
- Tamper and AC present monitoring
- Status LEDs
- Interlocking

1.2 Technical specification

Technical specification	
Relay contact rating	Main relay 5A / 50V AC AUX relay 1A / 50V AC
Indoor use only	
Compatible with ACTpro controllers	ACTpro-1500, 1520, 4000

1.3 Electrical specification

Electrical specification	
Input voltage	230VAC +/- 10%
Frequency	47-53Hz
Input fuse	625mA 250V anti-surge fuse
Output voltage	13.65V (+/-5%)
Max load	2A @ 25°C
Electronic output fuse	Yes
Battery current	~0.5A for a battery discharged to ~10V

Electrical specification	
Battery protections	Deep discharge/Over charge/Reverse polarity
Operating temperature	-10°C to +55°C

1.3.1 PSU output voltage

The PSU output voltage is 12V DC. The power supply provides two 12V outputs. One is pre-wired to power the ACTpro door station; the second is available to power locks. The full load current is shared between the two outputs. Vanderbilt recommend that a maximum of 1.5A is used to power locks and readers. The remaining 0.5A is used by the door station and battery charging. Total current from both outputs must not exceed 2A.

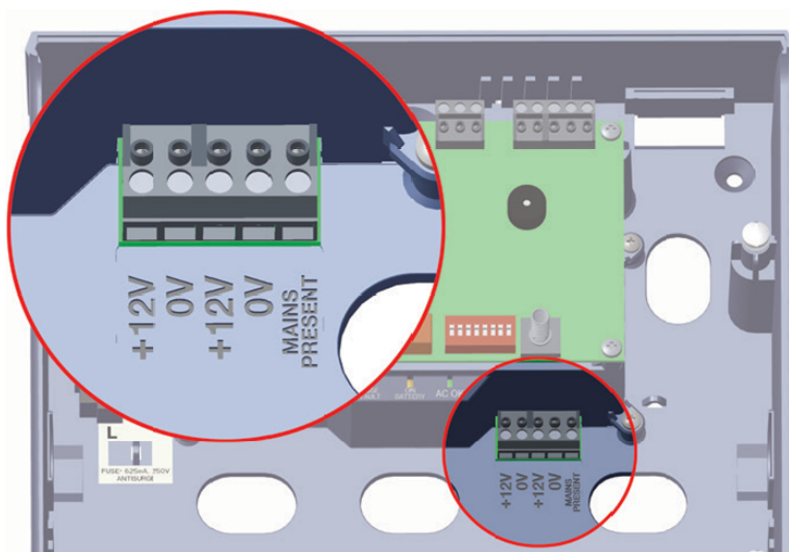

1.4 Power budget

The PSU 2A output current is used to power the door station and supply the battery recharge current. 500mA is reserved for battery recharge and to power the door station. Therefore 1.5A is available to power readers and the lock.

A complete access control system will require readers and a lock mechanism all of which will require power.

The following table should be used for calculating the power budget.

ACTpro reader (1030/1040/1050/1060)	100mA
ACTpro MIFARE reader (1030/1040/1050)	100mA
VR10S-MF, VR40S-MF readers	220mA
VR20M-MF, VR50M-MF Mullion readers	150mA
Typical mag lock (consult your supplier)	800mA

1.4.1 Example power budget

The power budget of a typical single door read in/out installation is:

Total current available	2000mA
Door station and battery recharge	500mA

Total current available	2000mA
Reader x2	200mA
Typical mag lock	800mA
Total consumption	1500mA
Spare capacity	500mA

1.5 Ordering information

Controllers	Product Code	Description
ACTpro-1500	V54502-C111-A100	Single door IP controller expandable to 32 doors with ACTpro door stations.
ACTpro-1500PoE	V54502-C112-A100	Single door IP controller with PoE + PSU.
ACTpro-1520	V54502-C110-A100	Controller with integrated 12V 2A DC power supply.
ACTpro-100	V54502-C120-A100	Door station, single door
ACTpro-120	V54502-C122-A100	Door station with integrated 12V 2A DC power supply, single door.
ACTpro-IOM	V54506-B100-A100	IO module (8 inputs and 8 outputs)

2 Installation

The ACTpro-120 door station is for indoor installation only and must be installed as permanently connected equipment.

An external AC disconnect device must be fitted. Before installation ensure that the AC supply to the ACTpro-120 door station is disconnected.

AC power should be connected to the ACTpro-120 door station by a licensed electrician in accordance with local/national codes.

2.1 Mounting

Mount the ACTpro-120 door station directly onto the wall with the supplied screws. The keyed mounting hole should be screwed first to the wall to aid the mounting.

The unit should be installed in a ventilated area that allows for accessibility after installation.

2.2 AC power up

1. Attach a correctly rated AC cable and fasten using the cable tie.

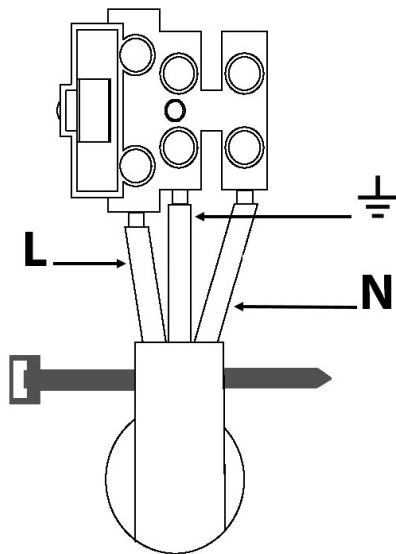

Use an approved external AC disconnect device.

2. Apply AC power.
3. Check the **AC OK** LED is on and measure the +12V output.

2.3 AC power up (USA)

1. Attach a correctly rated AC cable and fasten using the cable tie.

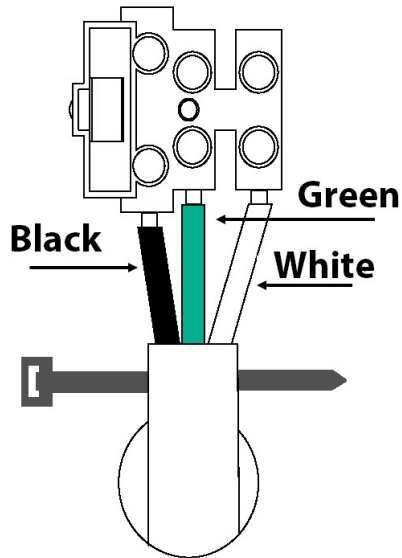

2. Use an approved external AC disconnect device.
3. Apply AC power. Check the **AC OK** LED is on and measure the +12V output.

2.4 Battery insertion

1. Disconnect the AC.
2. Ensure the battery has enough charge to supply the load.
3. Connect the red battery lead to the + battery terminal and the black lead to the – terminal.
4. Apply the AC power and check the **AC OK** green LED is illuminated.
5. Remove the AC power and check that **ON BATTERY** amber LED is illuminated.
If the amber LED is illuminated the battery is now supplying the output.
6. Re-apply the AC power.
The **AC OK** LED will illuminate and the **ON BATTERY** LED will extinguish.

3 Wiring

This section describes the following.

- 3.1 Wiring the ACTpro-120 9
- 3.2 DIP switch addressing 10
- 3.3 Wiring Clock&Data entry and exit readers 11
- 3.4 Wiring Wiegand entry and exit readers 12
- 3.5 Wiring Door Contact 13
- 3.6 Wiring Push Button (PB) 13
- 3.7 Break Glass monitoring only 14

3.1 Wiring the ACTpro-120

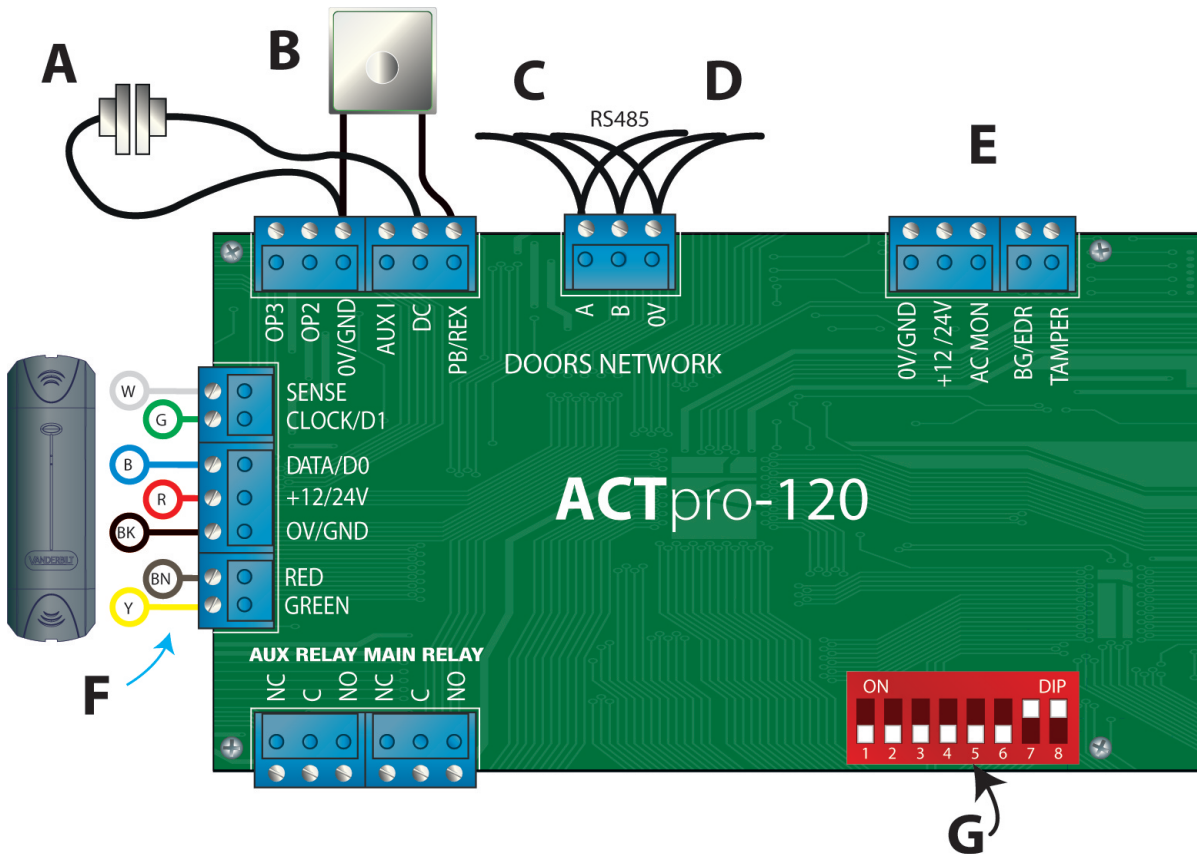

Label	Description	Label	Description
A	Door contact, normally closed	E	Break glass monitoring, normally closed
B	Push to exit, normally open	F	Vanderbilt reader wire colour coding
C	From previous door/controller	G	DIP switches for door station addressing
D	To next door		

3.2 DIP switch addressing

The first cell in each table row indicates the required address; the remaining cells in the row show the required placement of each DIP switch to configure that address.

	1	2	3	4	5	6	7	8
01	OFF	OFF	OFF	OFF	OFF	OFF	OFF	ON
02	OFF	OFF	OFF	OFF	OFF	OFF	ON	OFF
03	OFF	OFF	OFF	OFF	OFF	OFF	ON	ON
04	OFF	OFF	OFF	OFF	OFF	ON	OFF	OFF
05	OFF	OFF	OFF	OFF	OFF	ON	OFF	ON
06	OFF	OFF	OFF	OFF	OFF	ON	ON	OFF
07	OFF	OFF	OFF	OFF	OFF	ON	ON	ON
08	OFF	OFF	OFF	OFF	ON	OFF	OFF	OFF
09	OFF	OFF	OFF	OFF	ON	OFF	OFF	ON
10	OFF	OFF	OFF	OFF	ON	OFF	ON	OFF
11	OFF	OFF	OFF	OFF	ON	OFF	ON	ON
12	OFF	OFF	OFF	OFF	ON	ON	OFF	OFF
13	OFF	OFF	OFF	OFF	ON	ON	OFF	ON
14	OFF	OFF	OFF	OFF	ON	ON	ON	OFF
15	OFF	OFF	OFF	OFF	ON	ON	ON	ON
16	OFF	OFF	OFF	ON	OFF	OFF	OFF	OFF
17	OFF	OFF	OFF	ON	OFF	OFF	OFF	ON
18	OFF	OFF	OFF	ON	OFF	OFF	ON	OFF
19	OFF	OFF	OFF	ON	OFF	OFF	ON	ON
20	OFF	OFF	OFF	ON	OFF	ON	OFF	OFF
21	OFF	OFF	OFF	ON	OFF	ON	OFF	ON
22	OFF	OFF	OFF	ON	OFF	ON	ON	OFF
23	OFF	OFF	OFF	ON	OFF	ON	ON	ON
24	OFF	OFF	OFF	ON	ON	OFF	OFF	OFF
25	OFF	OFF	OFF	ON	ON	OFF	OFF	ON
26	OFF	OFF	OFF	ON	ON	OFF	ON	OFF
27	OFF	OFF	OFF	ON	ON	OFF	ON	ON
28	OFF	OFF	OFF	ON	ON	ON	OFF	OFF
29	OFF	OFF	OFF	ON	ON	ON	OFF	ON
30	OFF	OFF	OFF	ON	ON	ON	ON	OFF
31	OFF	OFF	OFF	ON	ON	ON	ON	ON
32	OFF	OFF	ON	OFF	OFF	OFF	OFF	OFF

Notes:

- Door 1 is reserved for the ACTpro-1500/1520 controller.
- Doors 1 and 2 are reserved for all other ACTpro-4000 controller.

3.3 Wiring Clock&Data entry and exit readers

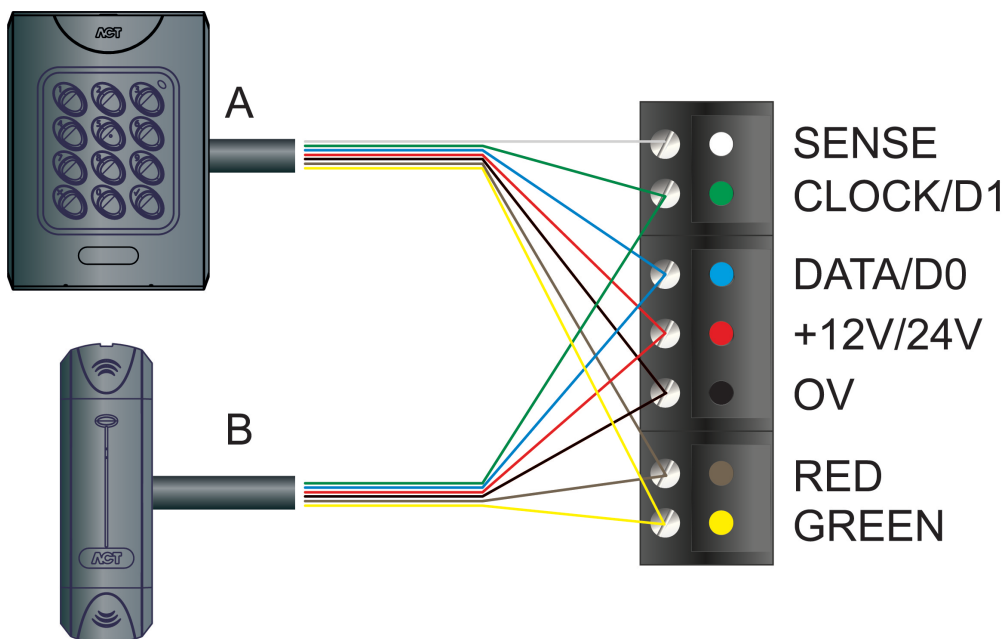

For Clock&Data readers, wire exit readers in parallel with entry readers, but leave the sense line unconnected for exit readers.

Max length: 100m with 12V DC

Cable: 8 core screened Belden 9504 (24 AWG) or equivalent.

Label	Description
A	Entry reader. ACTpro-1050 PIN and Proximity reader (EM1050, MF1050, EV1050).
B	Exit Reader. ACTpro-1030 Proximity reader (EM1030, MF1030, EV1030).

3.3.0.1 Terminal block wiring

Reader Terminal Block	Recommended Wiring colour	Controller Input PIN	Signal Information
SENSE	White	SENSE	For Entry readers connect the reader SENSE cable or terminal to the SENSE input pin. For Exit readers, do not use this input.
CLOCK/D1	Green	CLOCK/D1	This is the clock or strobe signal input on the ACTpro controller or door stations. Connect the reader CLOCK/D1 cable or terminal on the reader to CLOCK/D1 input pin.
DATA/D0	Blue	DATA/D0	This is the Data input. Connect the reader DATA/D0 cable or terminal on the reader to DATA/D0 input pin.
+12V/24V	Red	+12V/24V	Positive +12V DC Supply voltage for the reader.
0V/GND	Black	0V	0V Supply Voltage for the reader.
RED	Brown	RED	Red LED control output from the ACTpro controller or door stations. Connect the reader brown cable to the terminal marked RED on the controller.

Reader Terminal Block	Recommended Wiring colour	Controller Input PIN	Signal Information
GREEN	Yellow	GREEN	Green LED control output from the ACTpro controller or door stations. Connect the reader green cable or terminal marked GREEN on the ACTpro controller.

3.4 Wiring Wiegand entry and exit readers

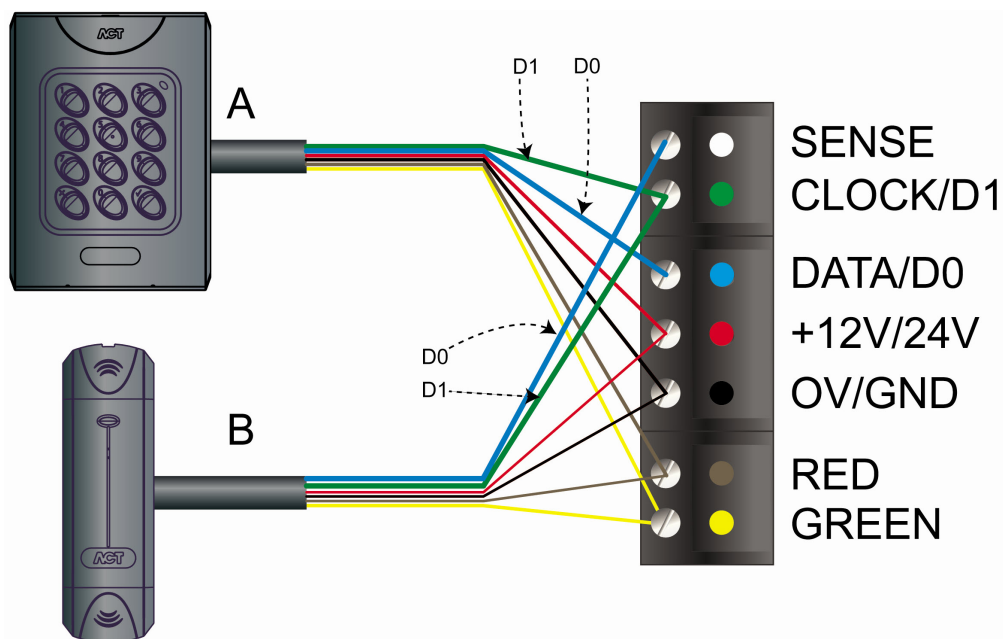

Label	Description
A	Entry reader. ACTpro-1050 PIN and Proximity reader (EM1050, MF1050, EV1050).
B	Exit Reader. ACTpro-1030 Proximity reader (EM1030, MF1030, EV1030). Do not connect the reader to the SENSE pin on the controller.

For Wiegand Entry Readers: Wire D0 to the DATA/D0 Pin on the ACTpro controller and D1 to the CLOCK/D1 pin on the ACTpro controller.

For Wiegand Exit readers: Wire the D0 of the exit reader to the SENSE pin on the ACTpro controller and D1 to the CLOCK/D1 pin on the ACTpro controller.

Max length: 100m with 12V DC

Cable: 8 core screened Belden 9504 (24 AWG) or equivalent

3.4.0.1 Terminal block wiring

Reader Terminal Block	Recommended Wiring colour	Controller Input PIN	Signal Information
SENSE	White	SENSE	For Entry readers connect the reader SENSE cable or terminal to the SENSE input pin. For Exit readers, do not use this input.
CLOCK/D1	Green	CLOCK/D1	This is the clock or strobe signal input on the ACTpro 1520/1500.
DATA/D0	Blue	DATA/D0	This is the Data input.
+12V/24V	Red	+12V/24V	Positive +12V DC Supply voltage for the reader.
0V/GND	Black	0V	0V Supply Voltage for the reader.
RED	Brown	RED	Red LED control output from the ACTpro 1520/1500. Connect the reader brown cable to the terminal marked RED on the controller.
GREEN	Yellow	GREEN	Green LED control output from the ACTpro 1520/1500. Connect the reader green cable or terminal marked GREEN on the ACTpro controller.

3.5 Wiring Door Contact

Connect door contact between DC input and 0V.

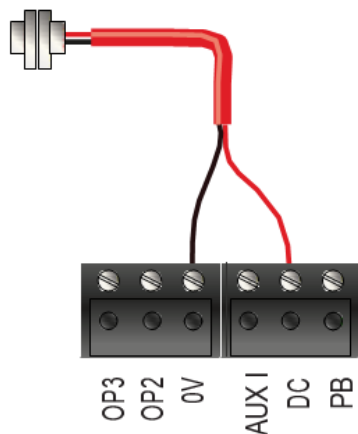

3.6 Wiring Push Button (PB)

Push button is connected between PB input and 0V. When push button is pressed the main relay is activated for the configured time.

Push button is also referred to as exit button, egress button, request to exit.

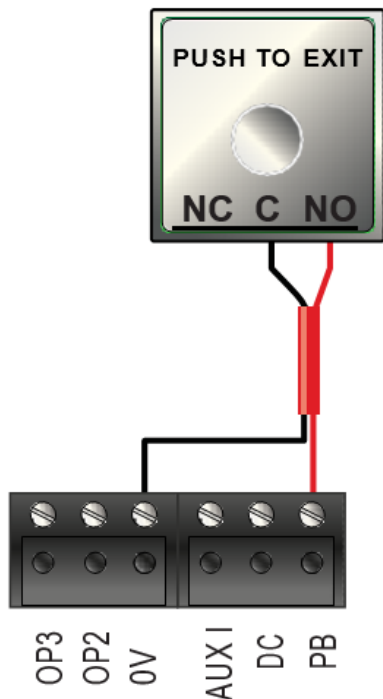

3.7 Break Glass monitoring only

The break glass monitoring features only monitors the break glass status and does not remove power from the lock. Vanderbilt assumes a double pole break glass unit is used, one pole to disrupt the power to the lock the second pole for monitoring.

When the break glass is not activated the B/GL input pin is held low at 0V. When the break glass device is activated the B/GL input pin will lose the 0V (goes high) and report a break glass event. The lock should be wired such that when the break glass is activated power to the lock is removed.

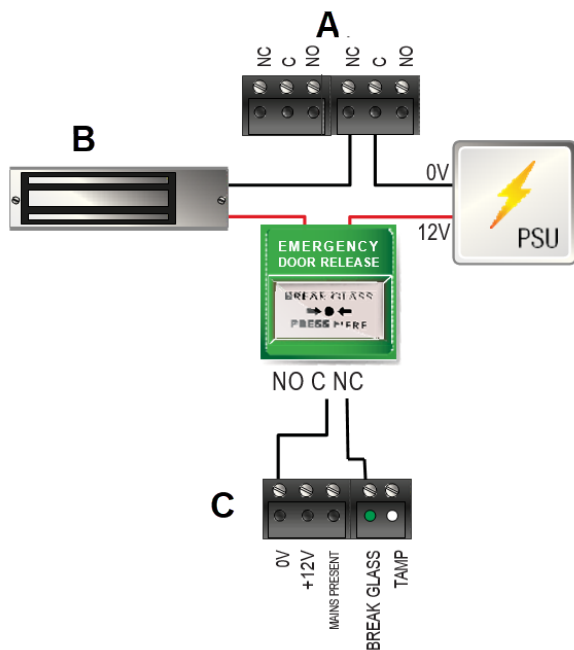

Label	Description	Label	Description
A	Relay	C	Break glass monitoring
B	Magnetic lock		

4 Monitoring

AC Present	The PSU AC PRESENT output is pre-wired to the AC PRESENT input of the ACTpro-120 door station.
Output Voltage	The PSU output voltage level is reported to the ACT Enterprise software and on the web browser.
Tamper	The enclosure lid is tamper monitored.

Note: All faults including **AC Present** and **Tamper** are reported on ACT Enterprise.

5 Status Indicators

Status indicators appear on the front of the ACTpro-120.

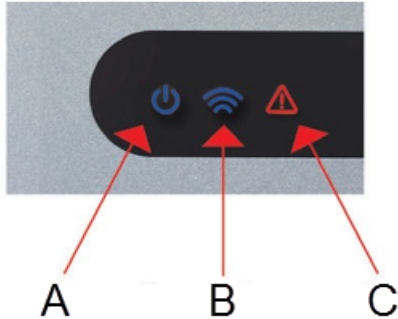

The meaning of each indicator is described below.



(A) Power / System Running

This indicates that the ACTpro-120 has power.



(B) Communications

Constant illumination indicates that the door station is online.



(C) Fault

Illuminates to indicate a fault on the system.

Possible causes are:

- Tamper open: Door station housing is not closed.
- Break Glass: The fault LED will illuminate if the emergency break glass switch is activated.
- Comms Offline: Door station is offline.
- AC Fault: ACTpro-100 door station will accept an AC present signal from a PSU (pre-wired on ACTpro-120). This is wired into AC PRESENT input on the PCB. When the PSU has no AC supply the fault is active.
- Low Supply Voltage: When voltage to the +12V terminal is less than +9V.
- Fuse Blown: The +12V output on the READER terminals is current limited to provide short circuit protection. The Fault LED will illuminate if too much current is drawn from this connection.

6 LED Indicators

- Green **AC OK**: Indicates that the AC power is within specification.
- Amber **ON BATTERY**: Indicates that the battery is supplying the output voltage.
- Red **FUSE FAULT**: Indicates electronic output shutdown fuse is active and that no power is being supplied to the load.

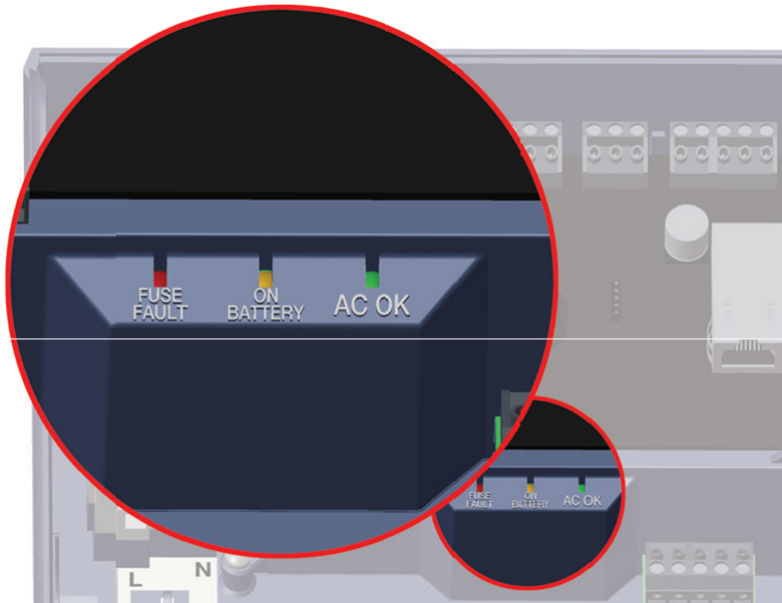

The maximum current that the PSU can guarantee is 1.5A plus 0.5A for battery charging. Beyond this the fuse will trip and the LED will stay on until the load is fully disconnected.

Once the load has been disconnected, remove devices to reduce the current demand below 1.5A.

It is important to calculate the power budget adequately. See *Power budget* on page 5 for more information.



© Vanderbilt 2020

Data and design subject to change without notice.

Supply subject to availability.

Document ID: A-100661

Edition date: 29.06.2020

VANDERBILT

vanderbiltindustries.com

 [@VanderbiltInd](https://twitter.com/VanderbiltInd)

 [Vanderbilt Industries](https://www.linkedin.com/company/Vanderbilt-Industries)

Issued by **Vanderbilt International Ltd.**
Clonshaugh Business and Technology Park
Clonshaugh, Dublin D17 KV 84, Ireland

 vanderbiltindustries.com/contact